

Stamford Scientific International
Diffused Aeration Oxygen Transfer Tests

Barcelona
Sept. 23rd - Oct. 9th 2003

INDEX

- 1. PURPOSE AND SCOPE**
- 2. DESCRIPTION OF TESTING PROCEDURES AND EQUIPMENT**
 - 2.1. SUMMARY OF METHOD**
 - 2.2. DESCRIPTION OF THE TEST BASIN**
 - 2.3 AERATION EQUIPMENT**
- 3. TEST PROCEDURE**
 - 3.1 DEOXYGENATION**
 - 3.2 MEASUREMENT OF OXYGEN TRANSFER**
 - 3.3 DATA ANALYSIS**
- 4. TEST PROGRAM AND CONDITIONS**
- 5. TEST DATA AND RESULTS**
- 6. CONCLUSIONS**

- ANNEX 1:WATER QUALITY**
- ANNEX 2:TEST CONDITIONS**
- ANNEX 3:EXPERIMENTAL DATA, DATA ANALYSIS AND REGRESSION CURVES**

- ANNEX 4:CALCULATION EXAMPLE**

- ANNEX 5: ORIFICE PLATE AIRFLOW CALCULATIONS**

1. PURPOSE AND SCOPE

Stamford Scientific International (SSI) of Poughkeepsie, NY, is a manufacturer of aeration equipment for the supply of oxygen to activated sludge wastewater treatment plants.

In an effort to acquire better knowledge and demonstrate performance characteristics of some of their new fine bubble aeration products, SSI has decided to conduct an extensive testing program to evaluate and compare oxygen transfer performance of the AFD270, AFD350 and AFT1000 fine bubble membrane diffusers.

Asesoría Técnica y Control (ATC) has been commissioned the conduction of a series of shop scale Clean Water Oxygen Transfer Tests on aeration systems representative of the Stamford Scientific International (SSI) line of fine bubble aeration products.

This document includes all the information regarding the tests conducted, the testing equipment and procedures followed, and the final results obtained for the different systems and conditions tested.

Tests were conducted by Ian Trillo and Jerónimo Cantón (ATC) between Sept. 23rd and Oc.10th 2003.

2. DESCRIPTION OF TESTING PROCEDURES AND EQUIPMENT

Shop Scale Clean Water Oxygen Transfer Tests are carried out by ASESORÍA TÉCNICA Y CONTROL's personnel in ATC's clean water testing facilities in Terrassa, Barcelona (Spain) following the procedures included in the ASCE Standard 'A Standard for the Measurement of Oxygen Transfer in Clean Water' (ANSI/ASCE 2-91).

2.1 SUMMARY OF METHOD

The test method is based upon removal of dissolved oxygen from the water volume by addition of chemicals followed by reaeration to near the saturation level. The dissolved oxygen inventory of the water volume is monitored during the reaeration period by measuring dissolved oxygen concentrations at several determination points selected to best represent the tank contents.

The data obtained at each determination point are then analyzed by a simplified mass transfer model to estimate the apparent mass transfer coefficient, K_{La} , and the steady state dissolved oxygen saturation concentration, C^*_{∞} . The basic model is given by

$$C = C^*_{\infty} - (C^*_{\infty} - C_0) \exp(-K_{La} \cdot t)$$

Where:

C = dissolved oxygen concentration, mg/l

C^*_{∞} = determination point value of the steady DO concentration at time approaches infinity, mg/l,

C_0 = DO concentration at time zero, mg/l, and

K_{La} = determination point value of the apparent volumetric mass transfer coefficient, 1/hr.

Nonlinear regression is employed to fit the above equation to the DO profile measured at each determination point during reaeration. In this way, estimates of K_{La} and C^*_{∞} are obtained at each determination point. These estimates are adjusted to standard conditions (20°C water temperature, zero DO concentration and one atmosphere) and the standard oxygen transfer rate (SOTR) is obtained as the average of the products of the adjusted determination point K_{La} values, corresponding adjusted determination point C^*_{∞} values, and the tank volume.

$$SOTR = \Sigma K_{Lai} \cdot C^*_{\infty 20} \cdot V_i$$

Where

SOTR= Standard Oxygen Transfer Rate, kgO₂/hr

K_{La20} = determination point value of K_{La} corrected to 20°C, 1/hr;

$C^*_{\infty 20}$ = determination point value of steady-state DO concentration corrected to 20°C and a standard barometric pressure of 1.00 atmospheres, mg/l;

V_i = liquid volume associated to each individual determination point when the aerator(s) is turned off.

The standard aeration efficiency (SAE), or rated of oxygen transfer per unit of power input, is often of interest and is computed by the following expression

$$SAE = SOTR / \text{Power Input.}$$

Oxygen transfer efficiency (OTE) refers to the fraction of the mass of oxygen in an injected air stream dissolved into the test fluid under given conditions. The standard oxygen transfer efficiency (SOTE) is the oxygen transfer efficiency corrected to standard conditions (20°C water temperature, zero DO and 1.00 atmospheres) and may be calculated for a given flow of air by

$$\text{SOTE} = \text{SOTR} / W_{O_2}$$

Where:

W_{O_2} = mass flow of oxygen in the air stream, mass/time (Kg/hr).

2.2. DESCRIPTION OF THE TEST BASIN

Asesoría Técnica y Control's (ATC) clean water test tank is an industrial (Shop) scale rectangular concrete tank, 7 metres long by 4 metres wide, with a total height of 7.5 metres. The tank dimensions are such that it is possible to represent a section of a full scale aeration system, thereby ensuring results are applicable to real full-scale conditions.

The compressed air fed to the aeration system is produced by means of a positive displacement blower (Aerzener Machine Factory GM 25S Delta Blower). For the purpose of testing, airflow to the basin is controlled using a control valve to by-pass to the atmosphere a portion of the compressed air stream in order to allow feeding of the desired amount of air to the aeration system. Airflow to test basin is measured by means of a calibrated orifice plate inserted in the air feed line, where a pressure gauge and thermometer are also present to allow for pressure and temperature corrections of the measured flow to standard conditions. During tests, airflow readings (differential pressure, flow, line pressure and line temperature), are taken manually every 5 minutes and the average flow for the duration of each test run is used for system performance calculations.

- 1 BLOWER
- 2 FLOW CONTROL VALVE
- 3 MANOMETER
- 4a FLOWMETER
- 4b ORIFICE PLATE
- 5 THERMOMETER
- 6 AIR SUPPLY
- 7 AERATION GRID

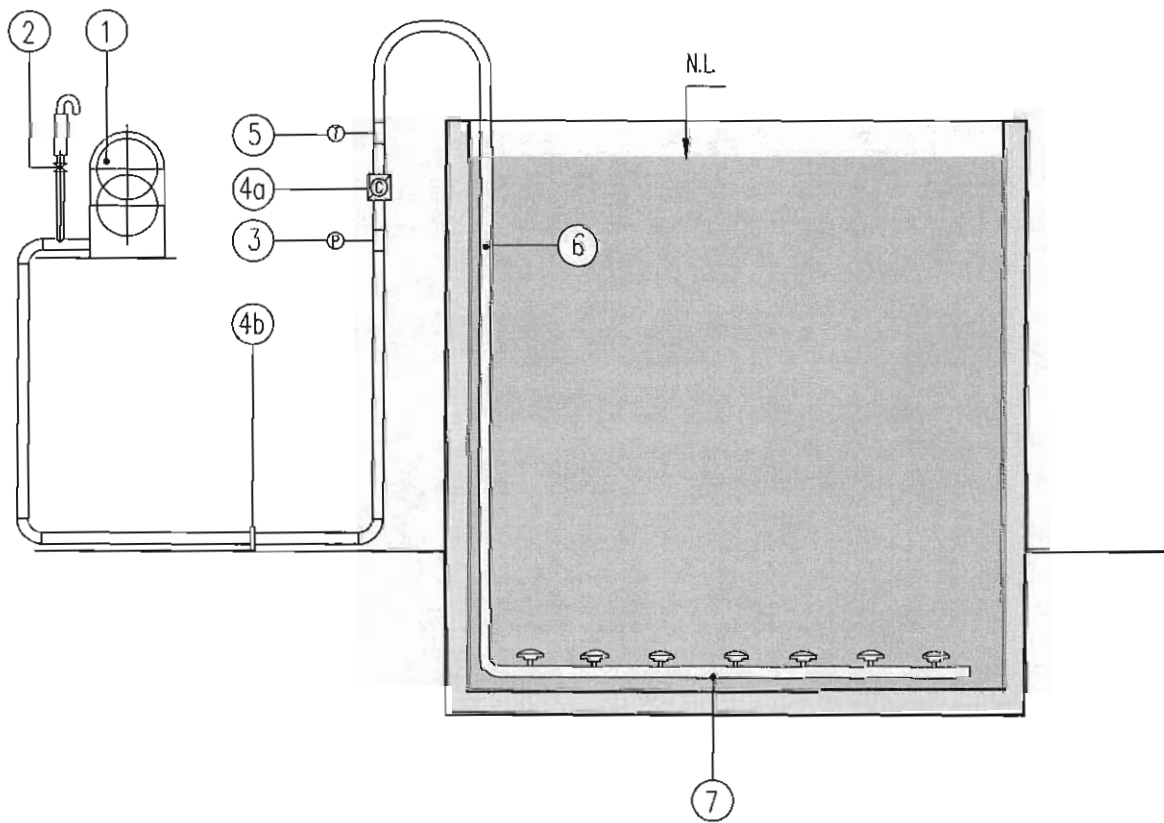

Fig. 1 SCHEMATIC OF TESTING TANK AND CONTROL DEVICES

The air distribution system to the test tank also includes an Endress+Hauser Prowirl 77 vortex flowmeter that can also be used for flow measurement. After previous agreement of all parties involved, vortex flowmeter readings have been used for flow measurement in some of the higher airflow tests due to orifice plate pressure drop measuring device limitations. For each test run, flow to the test basin was adjusted to +/- 2% of the target airflow value by opening or closing the by-pass valve to control the amount of air fed to the system.

2.3 AERATION EQUIPMENT

The type of aeration system to be installed in the test tank largely depends on the specific targets for each client/job. The air feed pipe to the basin is open near the bottom of the basin and is equipped with a standard DN100 flange to allow easy connection of most aeration systems in use. With a total tank bottom surface of 28 m², the system allows for good representation of most of the aeration system arrangements and densities usually installed in full scale STW.



The present series of tests has been conducted on a total of six different aeration systems based on installation of three different SSI Aeration products. Fine bubble diffusers of different geometry and size (AFD270, AFD350, and AFT1000) were used to build two aeration grids with each diffuser type, one grid allowing a total diffuser density around 14% floor coverage, and one second arrangement representing a 7.5% Active Diffuser Area/Tank Surface Area coverage. The six different diffuser layouts considered for the present series of tests are illustrated in the following schematics. In order to allow building the required test grids, original parts and diffusers have been made available by SSI. Installation of aeration equipment is done in accordance with manufacturer Installation Manual.

TABLE: DIFFUSER LAYOUTS FOR TESTING

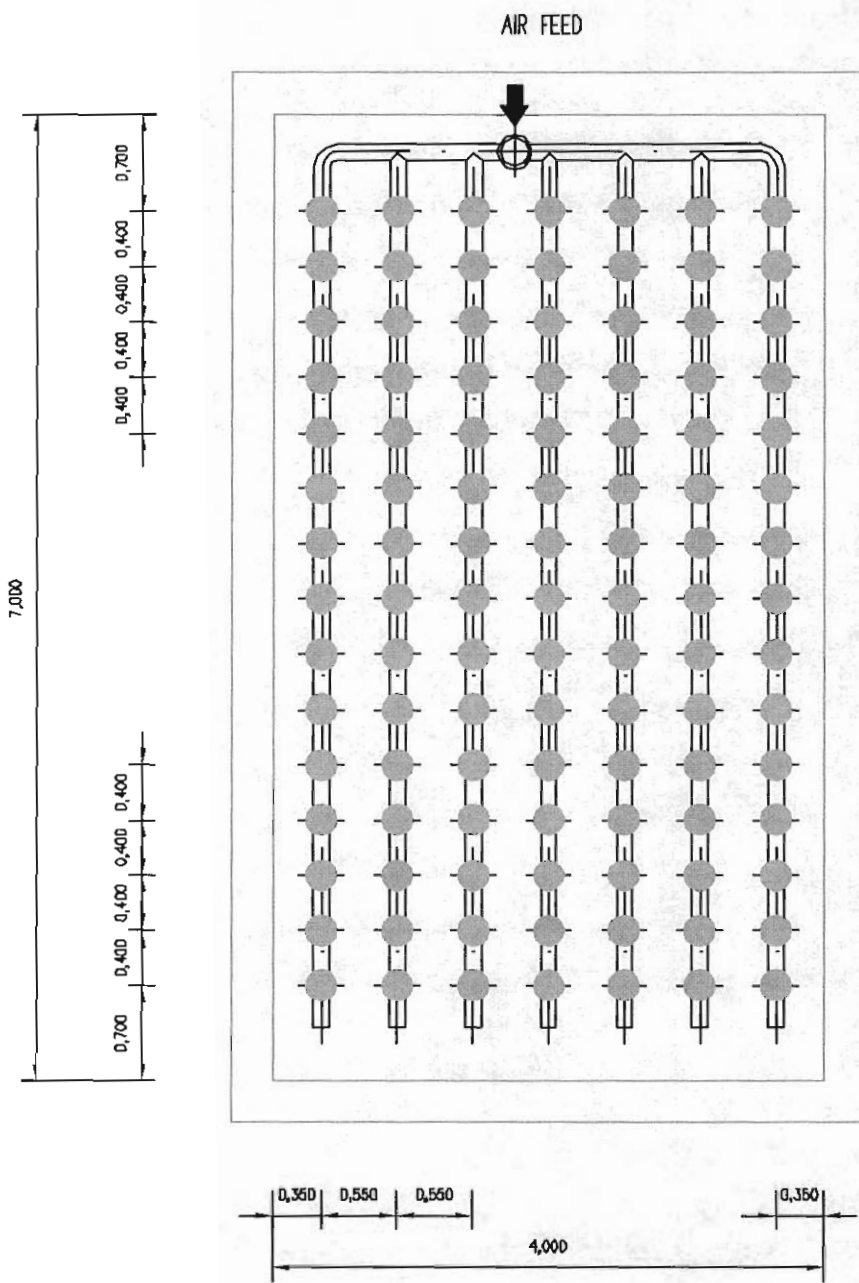

GRID	DIFFUSER TYPE	# DIFFUSERS	DIFF. DENSITY
1	AFD270	105	14.06%
2	AFD350	60	13.50%
3	AFT1000	16	14.20%
4	AFD270	56	7.50%
5	AFD350	32	7.20%
6	AFT1000	8	7.14%

After installation of the aeration system on the tank bottom support railings, the height of the diffusers over the tank bottom was measured before filling the tank to the specified operating water level.



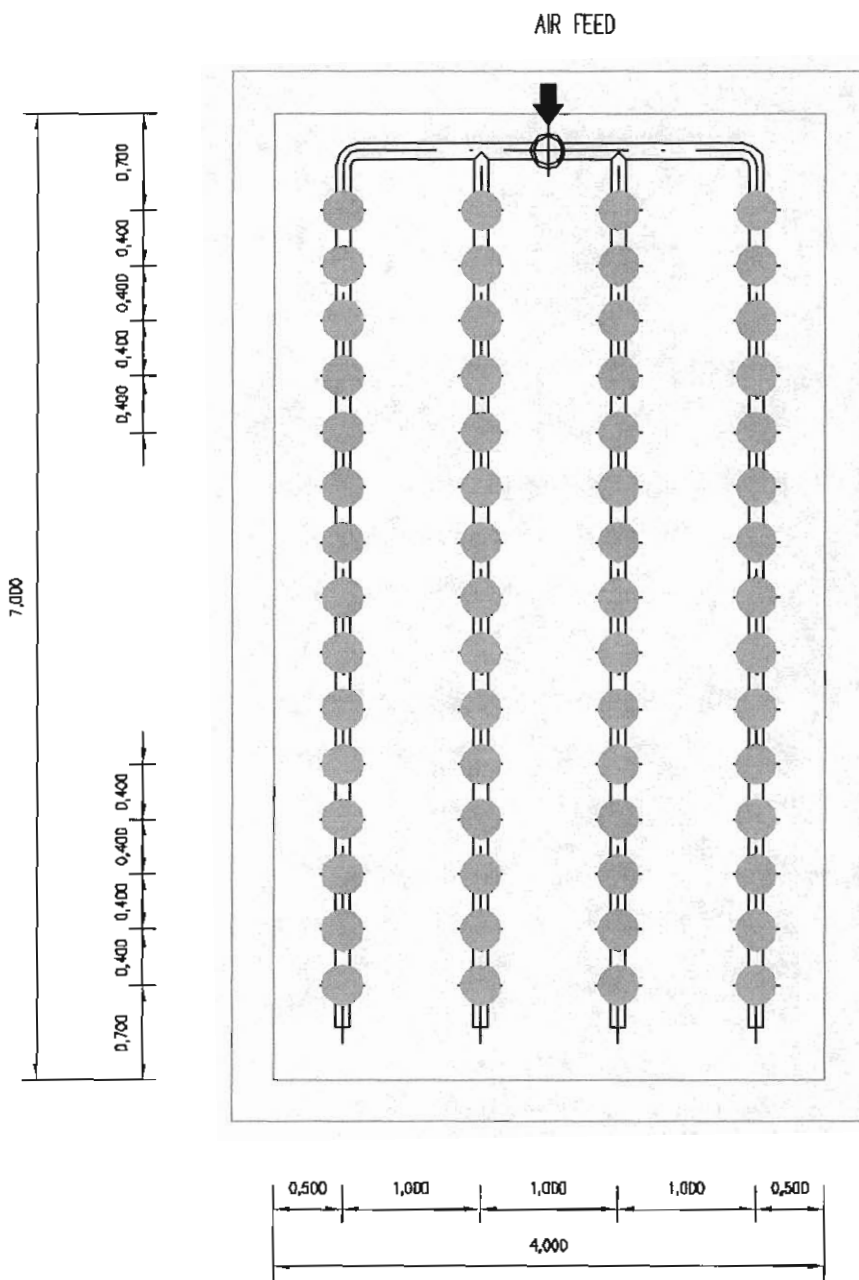

-  Active Diffuser
-  Plug

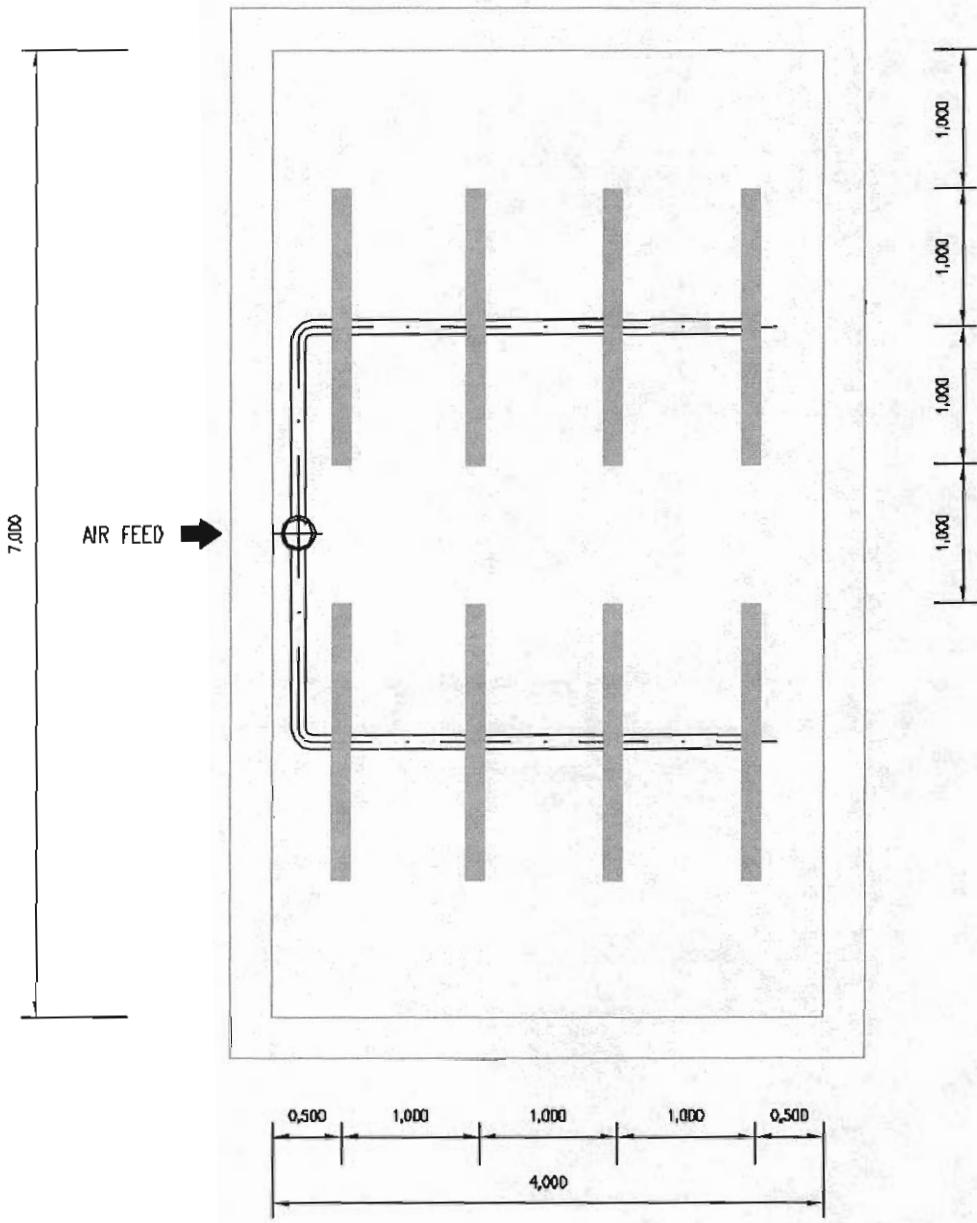

-  Active Diffuser
-  Plug

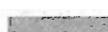

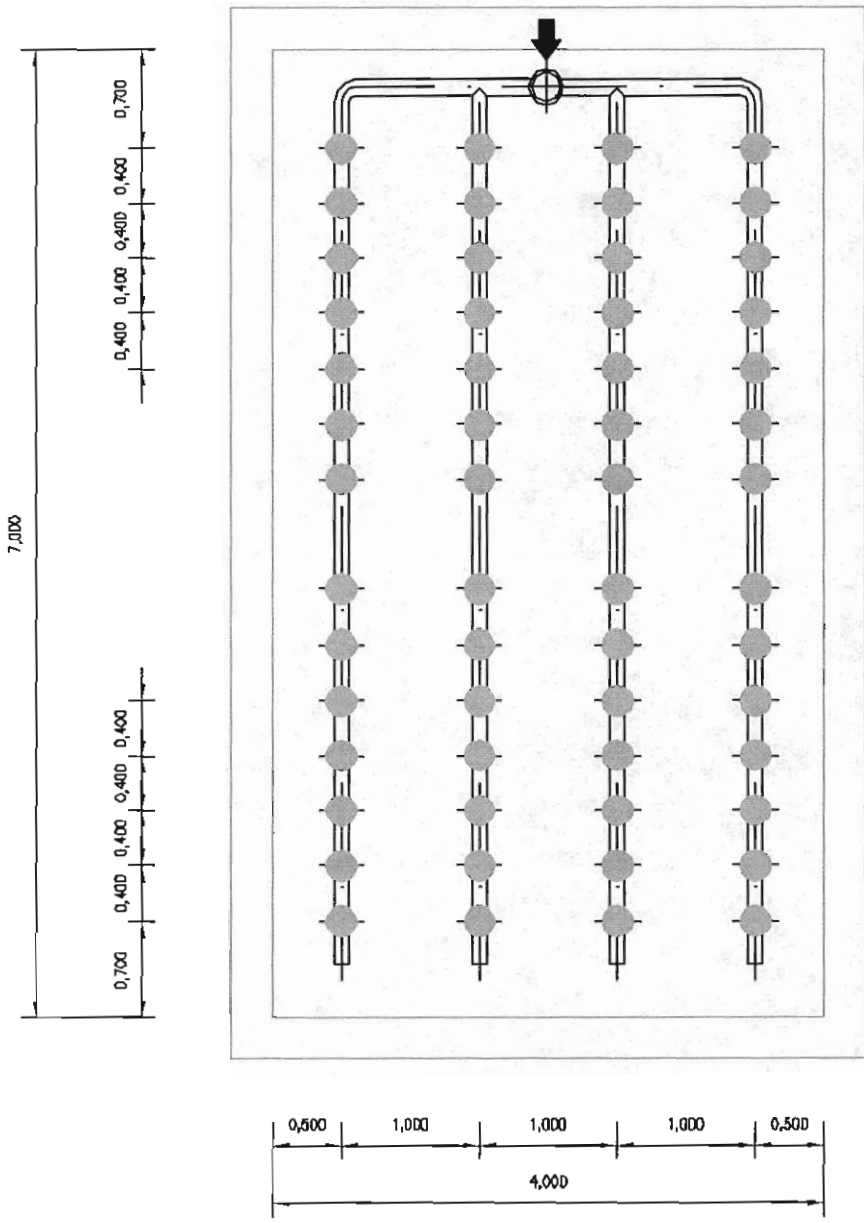

-  Active Diffuser
-  Plug

AIR FEED

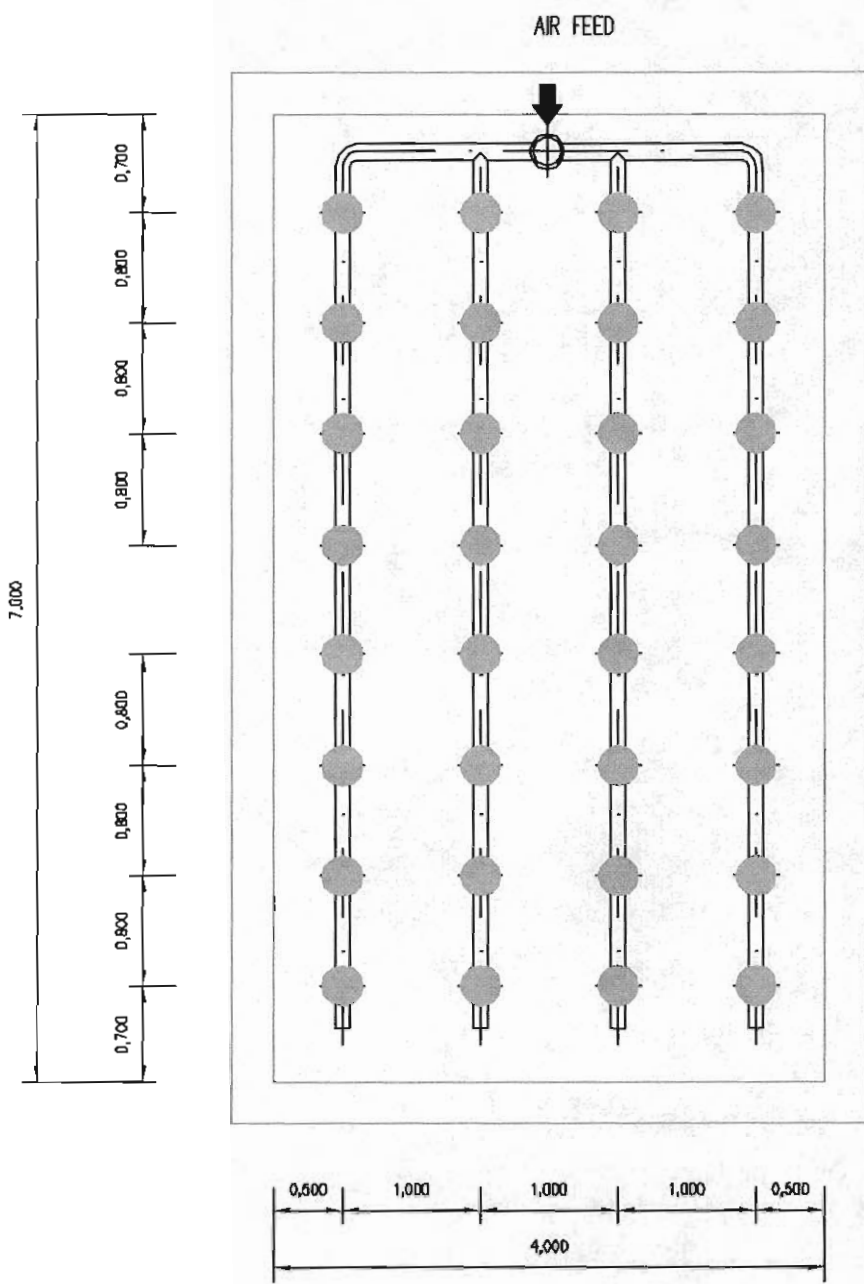

- Active Diffuser
- Plug



-  Active Diffuser
-  Plug

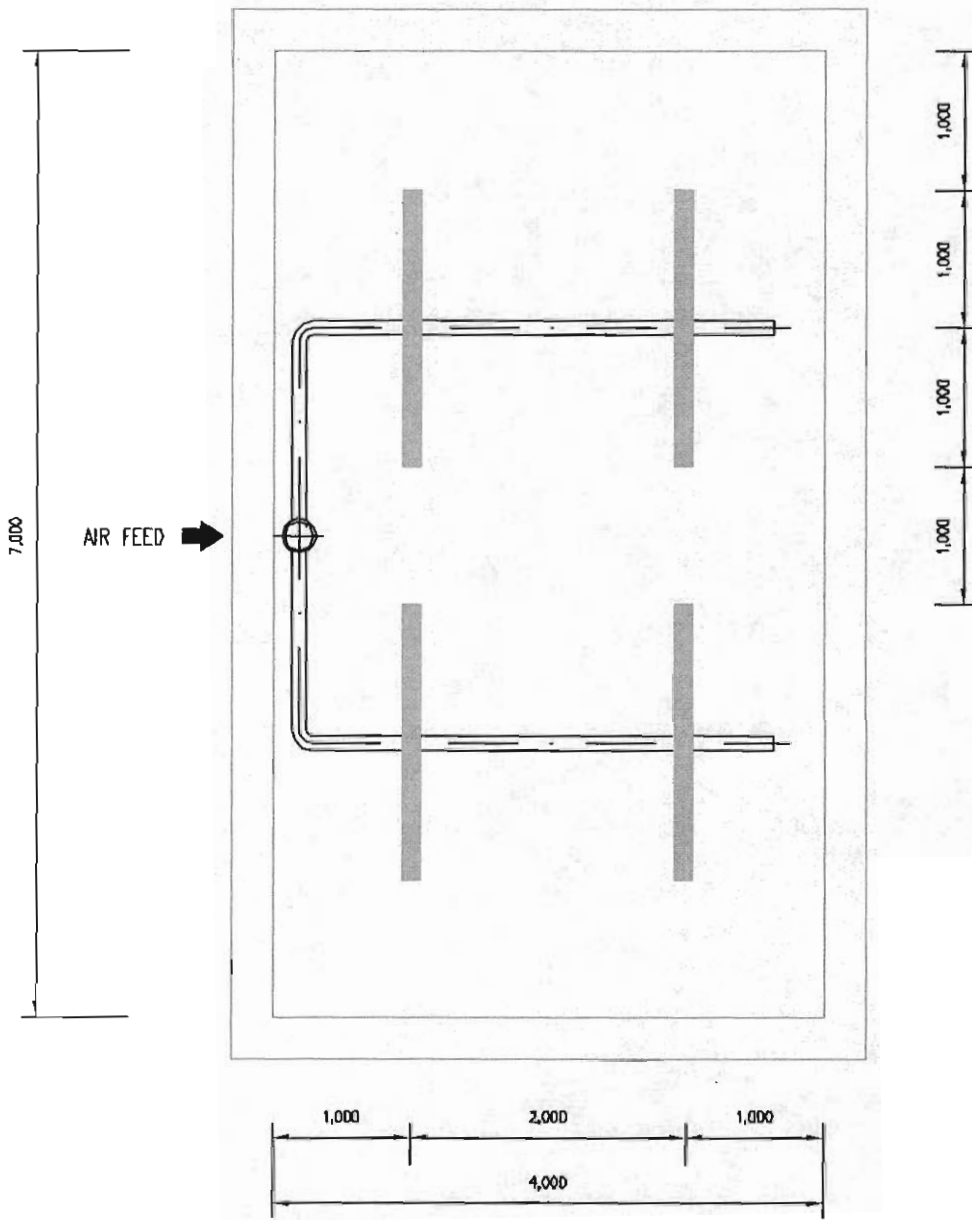

Active Diffuser

Plug

3. TEST PROCEDURE

The tests have been conducted following the procedures described in the ASCE Standard ANSI/ASCE 2-91 'A Standard for the Measurement of Oxygen transfer in Clean Water'.

Public supply drinking water from the area (Les Fonts, Mina Pública de Terrasa) was used to fill the test tank to the water depth specified for the tests. Multiple tests were conducted in the same water checking the conductivity did not exceed 3000 μS . Before reaching this limit, the test tank was emptied and refilled with fresh water from the same source before any further tests were conducted.

3.1 DEOXYGENATION

Deoxygenation of the test water volumes was achieved by addition of technical grade (98%) anhydrous Sodium Sulphite in excess of the stoichiometric amounts required for the removal of all DO present in the test water using Cobalt II Chloride $\cdot 6\text{H}_2\text{O}$ as a catalyst. To allow good catalisation, a minimum free cobalt concentration of 0,30 mg/l is maintained in the test volume. Cobalt catalyst was added to each batch of fresh water as a solution with the aeration system turned on at least one hour before the first addition of Sodium Sulphite to allow adequate mixing. Sodium Sulphite in excess of stoichiometric amounts required for DO depletion is added as a solution prepared beforehand in a separate mixing tank by pumping over the tank surface with a flexible hose. The aeration system was kept in operation at the desired test flow at all times, even during sulphite addition procedures.

3.2 MEASUREMENT OF OXYGEN TRANSFER

Determination of DO concentrations in the different areas of the test tank is accomplished by means of four Yellow Springs Instruments YSI 52 membrane DO probes. Precision, accuracy and response time of such probes is adequate for the application of the testing method used.

Location of DO probes in the test volume is represented in the attached drawing (Figure 3). Such distribution has been adopted to ensure good sampling of the test contents and representativity of the data collected. Calibration of probes was done by comparison with an independent DO measurement method (Winkler method). Winkler tests for probe calibration were conducted in ATC's facilities just beside the test tank. At the beginning of each test day, three water samples from the saturated test water were and analysed for Dissolved Oxygen concentration. The average of the three determinations was used to calibrate probes.

Data registration was done automatically connecting all probes to a laptop computer, and readings of the DO v/s time data points were taken at variable time intervals depending on the specific requirements of each test. The interval between readings was adjusted so that between 50 and 100+ data points were obtained for each test run.

3.3 DATA ANALYSIS

The data collected from each test is prepared for analysis following the truncation criteria contained in the applied standard and is analysed for K_{La} and C^* values using the non linear regression method.

Parameter values for each individual probe and test run are obtained and used for system performance calculations. K_{La} and C^* values are corrected to standard temperature and pressure conditions using the expressions included in the applied standard and SOTE (Oxygen Transfer Efficiency at 20°C, 1 atm) values are then calculated

TOP VIEW

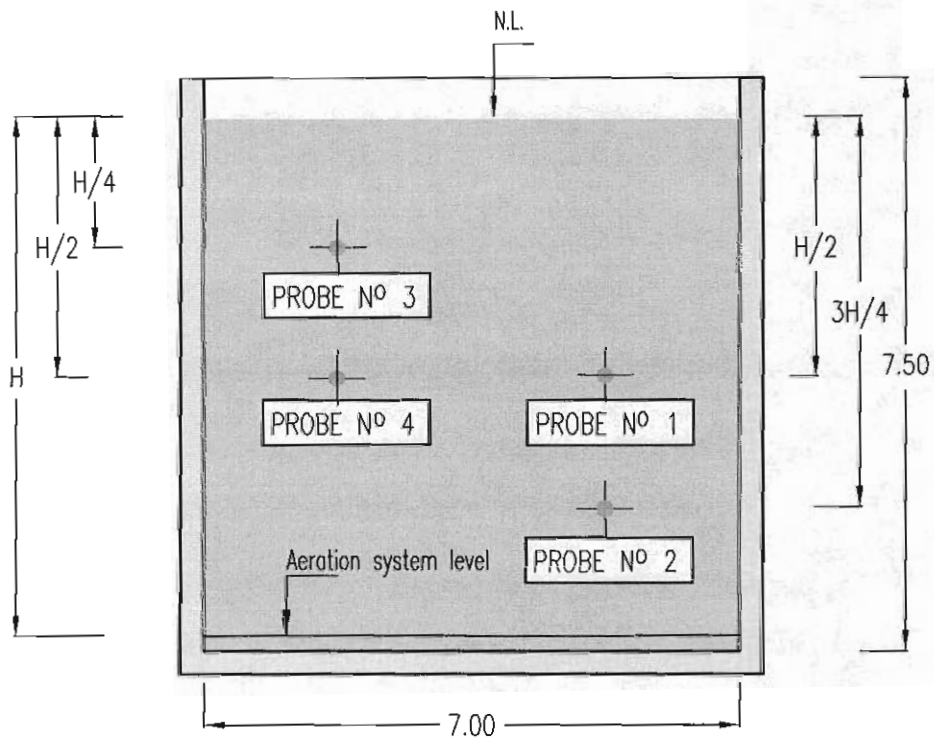
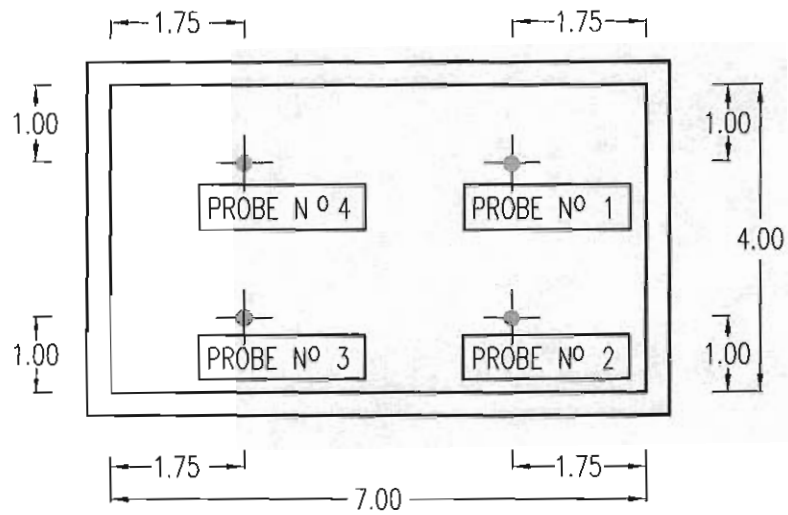

CROSS SECTION

Fig. 3 LOCATION OF DO PROBES IN TEST TANK

4. TEST PROGRAM AND CONDITIONS

Test program and system operating conditions depend on Client/Job-specific requirements. For the present series of tests, a program based on performing single test runs for the different aeration grids at different operating conditions has been designed. The proposed test program is as follows:

Aeration Grid	Test Runs	Test Ref.	Operating Airflows	Total Airflow, Sm ³ /h	Diff. Submergence, m
1	6	1a,1b,1c	1 each at 2,3 and 5 Sm ³ /h-diff	210,315 and 525 Sm ³ /h	4,00
		1d,1e,1g	1 each at 2,3 and 5 Sm ³ /h-diff	210,315 and 525 Sm ³ /h	7,00
2	6	2a,2b,2c	-	210,315 and 525 Sm ³ /h	4,00
		2d,2e,2g	-	210,315 and 525 Sm ³ /h	7,00
3	6	3a,3b,3c	-	210,315 and 525 Sm ³ /h	4,00
		3d,3e,3g	-	210,315 and 525 Sm ³ /h	7,00
4	6	4a,4b,4c	1 each at 2,3 and 5 Sm ³ /h-diff	120,168 and 280Sm ³ /h	4,00
		4d,4e,4g	1 each at 2,3 and 5 Sm ³ /h-diff	120,168 and 280Sm ³ /h	7,00
5	6	5a,5b,5c	1 each at 2,3 and 5 Sm ³ /h-diff	120,168 and 280Sm ³ /h	4,00
		5d,5e,5g	1 each at 2,3 and 5 Sm ³ /h-diff	120,168 and 280Sm ³ /h	7,00
6	6	6a,6b,6c	-	120,168 and 280Sm ³ /h	4,00
		6d,6e,6g	-	120,168 and 280Sm ³ /h	7,00

Other test conditions such as ambient temperature, barometric pressure, water temperature, etc, are also monitored during testing in accordance with the applied standard (See attached Table)

G3MAX4	3	521.4	21.4	992	4.00	21.85	5.46
G3AVG4	3	315.7	21.1	992	4.00	22.10	5.53
G3MIN4	3	214.5	21.2	992	4.00	23.73	5.93
G3MAX7	3	525.8	21.7	999	7.00	32.69	4.67
G3AVG7	3	313.6	21.6	999	7.00	36.51	5.22
G3MIN7	3	209.6	21.5	999	7.00	37.77	5.40

G6MAX4	6	279.5	18.4	996	4.00	18.14	4.54
G6AVG4	6	166.3	18.2	996	4.00	21.00	5.25
G6MIN4	6	111.4	18.1	996	4.00	22.12	5.53
G6MAX7	6	281.9	18.7	1000	7.00	29.97	4.28
G6AVG7	6	167.2	18.6	1000	7.00	32.71	4.67
G6MIN7	6	112.58	18.7	996	7.00	34.97	5.00

6

When analysing the data obtained, it is interesting to consider the fact that AFD270 and AFD350 diffusers have shown very similar performances both quite far away from the tube diffuser performance (around 15-20%). This fact is not surprising in itself as comparison of diffuser layouts was based on considering the whole of the tube diffuser as active when establishing the surface area of membrane required to match the densities obtained with the disc diffusers.

With regard to this issue, the data obtained in the present series of tests may be of help when trying to determine the basis for equivalence between tube diffuser membrane area and corresponding disc diffuser area.

Barcelona, October 28th 2003

The Engineer in Charge of the Testing



Ian Trillo

Asesoría Técnica y Control, S.A.